

GE1 Buckle Inside Release Handle

Features

- A neat, automotive design which is very easy to fix. There is no locking feature, so it is used on doors where inside locking is achieved by sill-button or other means
- Two styles of non-handed connector available – threaded or snap-in
- Semi-plant-on for easy installation, cushioned action and choice of finish options
- Lift flap to withdraw latch connection point 'X'
- Handle is bolted to inside door skin through base, and connected to latch
- Trim panel is fitted, and moulded escutcheon is slipped over 'buckle' and secured through centre hole, concealing edges of panel

Material

- Buckle: Bright chromium plated or black zinc plated
- Escutcheon bowl: Black ABS

Notes

- A rubber buffer on the frame acts as a stop, 'cushioning' action and preventing rattle
- Escutcheon bowl **GE1-G22324** sold separately
- Connector rod **G00078** (3.5 mm x 1 m) also available separately



&

GE1-G22324
(Fitted escutcheon bowl)

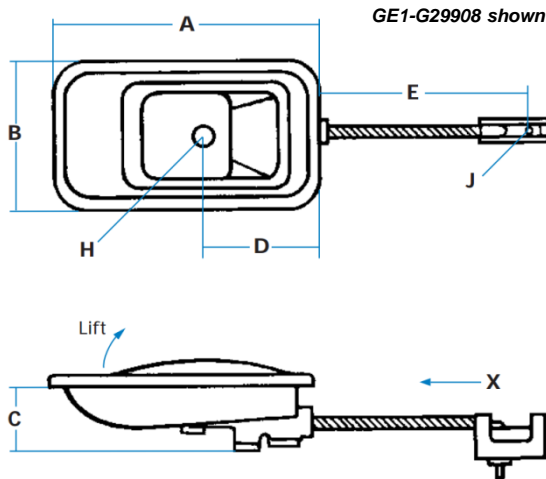

Installation of 'buckle' release

Illustration shows inside handle with simple connection to latch.

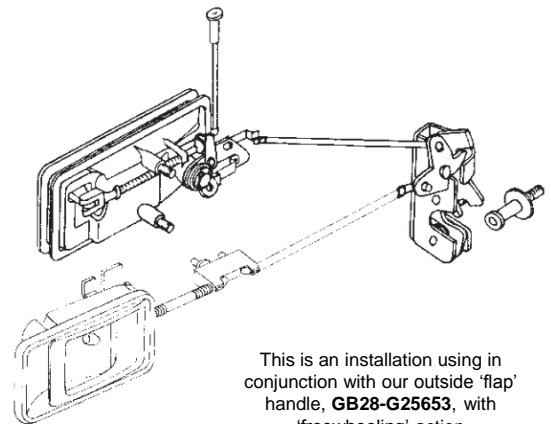

This is an installation using in conjunction with our outside 'flap' handle, **GB28-G25653**, with 'freewheeling' action

Part No.	Connector	Material	A	B	C	D	E	H	J	K
GE1-G29908	Snap-in	Chrome	102	55	23	45	75	5	3.5	15
GE1-G29908B		Black								
GE1-G00708	Threaded	Chrome								
GE1-G00708B		Black								